

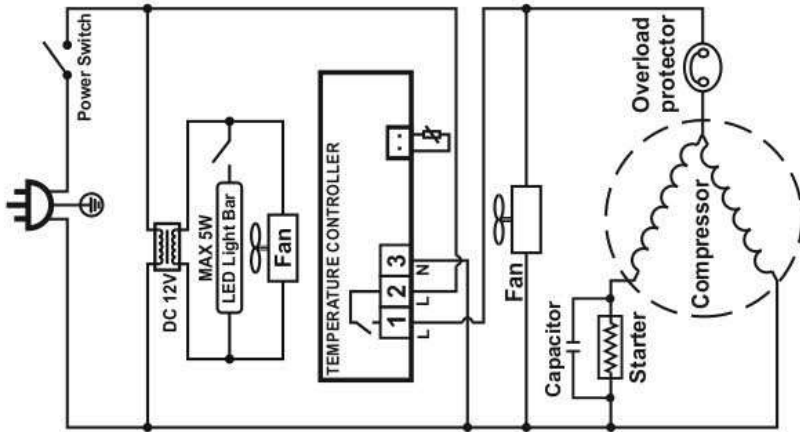

www.kayalarmutfak.com.tr

BACK BAR COOLER

ELECTRIC CIRCUIT DIAGRAM



MODEL	LG-208HE
TEST ROOM CLIMATE CLASS	CC2
M-CAN TEMPERATURE CLASS	K1
PROTECTIVE CLASSIFICATION OF ELECTRIC SHOCK RESISTANCE	I
DEGREE OF PROTECTION AGAINST INGRESS OF WATER	IP X0
RATED VOLTAGE	220-240V~
RATED FREQUENCY	50Hz
NET VOLUME	196L
GROSS VOLUME	207L
RATED INPUT POWER	160W
RATED CURRENT	0.78A
LAMP POWER	MAX 5W
REFRIGERANT	R600a(22g)
ENERGY CONSUMPTION	1.35kWh/24h
INSULATION BLOWING GAS	CYCLOPENTANE
NET WEIGHT	??kg